

RESPONSIBLE DESIGN: RE-USING/RECYCLING OF CLOTHING

Clare HUSSEY¹

Pammi SINHA² and Fiona KELDAY³

¹Consultant

²School of Materials, The University of Manchester, ³Centre for Remanufacture and Reuse

ABSTRACT

Textile and clothing recycling and reuse is an under researched field, but there is a growing body of literature driven by government concerns and policies about waste management. Studies (ERM, 2007) have noted that the environmental impacts arising from the disposal of clothing to landfill is significant enough to warrant a thorough examination of the opportunities for improving the reuse and recycling of clothing. Three issues have been identified that influence the management of textile waste: government (trade tariffs and policies); company (e.g. corporate social responsibility, location of production or manufacture); consumer (trends, tastes, spending capacity)

This paper reports the initial findings of research for the Centre for Remanufacturing and Reuse (CRR) 'Uniform Reuse' project: the process at a textile recycler in London with landfill waste of no more than 1% of its daily tonnage collected. The process is displayed as an IDEF chart developed through a site visit and interview with the directors of the firm who are involved in the daily activities of the process. Some of the issues raised are: the capacity for waste disposal – shipping 545kg of waste fabric on a daily basis, the (somewhat surprising) seasonal nature of the process, the amount of market research required for effective reuse, the necessity for developing customer relationships over a prolonged period of time, and the need for developing government policies to support and regulate the legitimate collection and use of waste. We highlight the implications for fashion design, e.g. use of natural fibres, difficulties of recycling synthetic fabrics (taking into account the development of closed loop polyester recycling at Patagonia and Teijin) and discuss some of the solutions being developed.

Keywords: textile recycling process, fashion design and reuse

1 INTRODUCTION

Consumption of textiles is 24.16m tonnes, on average 35kg per capita and expenditure on clothing has risen by 34% between 1996-2005; textiles is the fastest growing sector in household waste. Over the last ten years, discounting and low retail prices led to increased sales of clothing have increased by 60%, resulting in a proportional increase in levels of waste. The report by ERM (2007) advises that consumers be better educated about the environmental impact of discarding unwanted clothes and consigning them to the landfill. Indeed consumers are becoming increasingly aware of social/ethical issues such as the potential links between low costs and labour conditions, the FairTrade brand etc.

However, while there is a need for more information to be made available to the consumer about environmental impact of end-of-life clothing and textiles, there is also a need for the conception stage of fashion design to be more aware of the end-of-lifecycle management of fashion to encourage a 'cradle-to-cradle' vision.

Recent evidence on the sustainability impacts of clothing, (University of Cambridge, 2006, Oakdene Hollins, 2007, ERM, 2007 and Forum for the Future, 2007); unanimously agree the significant part that the secondary textiles industry and the consumer play in the textiles waste management effort. Buying second-hand clothing and textiles where possible, disposing of used clothing and textiles through recycling businesses (for second-hand selling or extracting and recycling the yarn or fibres) are two of the list of eight recommendations made for the 'ideal consumer' (University of Cambridge, 2006).

Oakdene Hollins report (DEFRA 2007) noted that the secondary textiles industry sorts and distributes used textiles into some 140 different grades, with five main categories:

- Re - use - wearable items resold in the UK through retail shops (considered the ‘cream’ of used textiles).
- Export Re - use - wearable items exported for resale in second - hand ‘retail’ outlets and markets (second-hand market)
- Wiper Grade - material suitable for use as rags and wipers with little or no further processing.
- Recycling Grade - material suitable for pulling or shredding into fibres for use in new end products
- Waste - material that cannot be resold or recycled which is disposed to the waste stream.

ERM (2007) concluded that re - use is better than recycling or disposal in landfill and substituting virgin fibres via recycling (or new clothing via re - use) has a high potential for greenhouse gas reduction. The UK government, through DEFRA, is taking action to “identify, understand and address sustainability impacts from products, services and materials consumed and used in the UK” (<http://www.defra.gov.uk/environment/consumerprod/products/clothing.htm>) to examine roadmaps for ten product areas with high negative impact on the environment: textiles/clothing is one.

2 THE CASE STUDY: LAWRENCE M BARRY & CO (LMB)

LMB & Co is a textile waste recycling firm in Canning Town, London. The site visit took place in July 2008, for three hours and was conducted with the manager and director (and daughter and son of Lawrence M Barry), Michelle Goggi and Ross Barry. The interview was recorded, photographed and transcribed. The process was examined and drawn up according to IDEF₀ modelling principles (Bin Akasah and Amirudin, 2006). Figure 1 illustrates the activity box for IDEF process model. Each process is labelled as an activity with inputs and outputs of the process and factors that serve to constrain or drive the process.

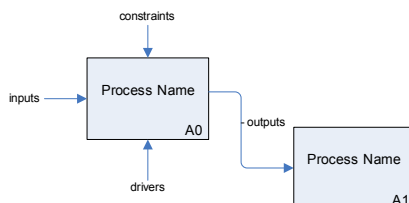

Figure 1: activity box for the IDEF process modelling technique

LMB was established 1985 with three members of staff and, although still a family run business, has evolved into 170 staff and three companies:

- LMB recycling plant,
- Britannia Plant and Engineering Ltd that fabricates the recycling receptacles and conducts mini-sorting,
- LMB Supplies which manufactures and supplies wiper cloths and ecological greened janitorial supplies.

2.1 The Textile Recycling/Reuse process at LMB

Figure 2 illustrates the three broad phases: collection, sorting and distribution. During the sorting phase, decisions are made regarding the final destination of the item: reuse, recycle or landfill. On average, each item that goes through the LMB system gets handled seven times.

Phase A1: collection

Figure 3 illustrates the process of collection of rags from LMB static banks at sites within the M25. Once into LMB vans, they are weighed on LMB weighbridge, recorded, and reported to the local authority once a month. The council claims their credits and LMB make a payment for the tonnage received. This payment does not take into account the state of the rags (often of poor quality - contaminated or

damaged.) Once weighed, clothes and miscellaneous items are tipped off the back of the van and sorted. Any paired shoes and bags are removed and are sorted separately. Items are sent up a conveyor belt to the first floor where there is a large caged area in which all the clothes are deposited and stockpiled; where necessary they are de-bagged.

Phase B: sorting

In this phase items are separated into shoes/textiles products and if they can be reused, recycled or need to be sent to landfill. In this phase, two types of sorting take place simultaneously: a textile products sort and shoe sort. Figures 4(i) and 4(ii) illustrate the details of the processes of shoe and rag sorts.

Stage B1: shoe inspection

For LMB, unpaired shoes or very badly damaged and unrepairable shoes are sent to landfill as to recycle shoes parts is not yet possible and potentially very toxic to the environment.

B11 shoe sort

Paired shoes are sorted by gender and age (men's, women's, children's) then by type, and by quality grade 1 or 2. Men's shoes are more in demand, (ladies' are much higher turnover - many come through still with the tags on them, unworn). Shoes with holes are still useful as they can be repaired in the destination countries. Shoes are bundled together in clear, see through plastic mixed 30kg bags so that receiving customers can see easily the content of the bag. The sorters need to have good destination market knowledge: e.g., heeled women's shoes are sent to Eastern Europe, while in African countries, the environment it is not really suitable for high heels, so flatter shoes are sent there. They have problems obtaining children's shoes. On the wall, vintage style shoes are displayed to inform the sorters to help them bundle appropriately.

Stage B2 - 'chute' sorting

All goods are hand sorted then thrown into the appropriate shoot to a container on the floor below where bundles are created for final dispatch. Clothing and any domestic articles are sent down the chute to be separated.

B21: 'rag sort':

A quick sort: items for reuse (curtains, nets, pillowcases, handkerchiefs etc) or recycling goes down a separate belt where the goods are sorted into particular categories) and those unsuitable for either are removed (destined for landfill).

B211 Recycling:

Absorbent items (soiled/torn t-shirts, sweatshirts) are separated out to be made into wiping/cleaning cloths. Flocked and wool items are sorted for their specific end use. In order for flocking to take place, an item must have a minimum of 40% wool to utilise it in any way. It is sent to be processed into shoddy, where the processors conduct tests to ensure this as the end product is used for wool based fire retardant fabric, e.g. by bed manufacturers and the automotive industry. Knitted products such as jumpers are sent to be remade into knitting wool by pulling machines at external processors. White jumpers have more value as they can be coloured to the latest trends most directly. If the quality and style are particularly good, they may be bought by buyers.

B212 Reuse:

- Items on the conveyor are sorted by a team of trained 'useful sorters' by garment type (not brand labels), if not suitable, they are put into shoots for the recyclable items.
- Each garment type is placed into one of 160 box/cage categories; dictated in part by the market they are selling to, indicative of the level of destination market knowledge required, e.g., clothes that command a premium in the UK, may have no market value to any of the LMB customers, short skirts may not be popular/worn in Africa.

- Garment types are also categorised in a variety of descriptors, e.g.: light weight polyesters, accessory type items, formal trousers. Each type of garment tends to have a 'destination', with warmer winter type clothing going to the mountainous countries, and the lighter weight items being sent to the African countries.
- For more formal garments, the items are graded into types, e.g., trousers with a crease and turn up command a higher price. Also the trousers are made into smaller bundles and folded carefully on the crease to avoid excessive creasing during the transportation phase.
- With leather coats, if the leather is of good quality the jackets are likely to be sold on, deconstructed and created into new products.
- Feathers are no longer recycled in the UK as it is cheaper to buy new feathers from China. All the feathers LMB collect are sent to Belgium.
- Any items that are wet are dried out before they are bundled - if bundled when wet, they mould, generating heat and potentially combustible causing hazard as shipments can be on the seas for five or six weeks.
- Items to be bundled come down the shoot, with the appropriate label explaining exactly what is in the bundle.
- The bundles are bagged up into 45kg bales (or smaller if they are trousers), as they may have to be carried by hand once they reach their destination.
- Items are put into a compressor, sealed in plastic and bound to standard dimensions; as one is compressed, the next load will be dropped.
- Prior to dispatch, the larger bales are rapped in duvets and sleeping bags to utilise them.

Phase C: distribution

- Shipment - ideally, they process a 40 foot container per day, which is around 500 bales, or 400 bales and the rest of the space filled with 'shoe sacks'.
- Re-cycling - items may be made into shoddy (woollen), re-knitted (jumpers/pullovers) or made into wipers (absorbent, stained or torn clothes, e.g. Tee shirts, sweat shirts, etc), LMB Supplies manufacture 16 grades of wiper cloths.
- Landfill - LMB rarely send textiles to landfill unless they are heavily contaminated, some 5-10% of the collected materials is waste, of which less than 1% is textile waste. Landfill is the least desirable and final resort for LMB as there will be landfill charges as well as the environmental concerns.

3 ISSUES RAISED FROM THE CASE STUDY:

Collection

- LMB only collect from within the M25, to maintain low carbon footprint.
- LMB prefer public donations in re-used supermarket sized plastic bags (keeps clothing dry and free from contamination), rather than black bin liners (virgin material) that tend to jam up their conveyor belts.
- Donation seasonality: affect quantities, e.g.: before holidays, after holidays, when it rains. Pre-Christmas is very quiet but post-Christmas is very high.
- Level of recycle/reuse: Ms Goggi estimated approximately 60% of the content of a collected bin can be re-used, 40% can be recycled. For a container, between 5-12% waste, of which below 1% is textile waste, the remainder tends to be household rubbish which is regularly bagged up with the clothes. Although little to be done to avoid deliberate misuse, to avoid offal and other waste within the bins spoiling the collections resulting in them being landfilled, unnecessary expenses and harm to the environment, LMB suggest clearer public guidelines on what can/can't be recycled within their bins.
-

Business performance

LMB prides itself on the relationships that they build and maintain with their customers across the world. Operating in the secondary textiles is a B2B business, not a charity. LMB buys the goods that it sorts then sells, whereas charities sell their received donations to merchants, who may not process the goods for recycling and reuse as thoroughly as LMB. This has repercussions on business performance. LMB purchase donated apparel and footwear goods by the tonne from the London borough councils. This used to be around £50 per tonne, however, this is being driven up by traders paying up to £200-300 per tonne, who do not sort their collections and send waste textile products into Eastern Europe, for processing or disposal. There have been instances where Eastern European countries having obtained goods from the UK, sort and create wipers, which they try to sell back to LMB for redistribution.

Public education about secondary textiles industry activities

In the last four years LMB have introduced an 'education' arm (set up as a community interest company), which works with the local authorities. LMB's 14 coordinators go into around 600 schools where they provide creative workshops to aid understanding of recycling and reuse, free recycling service in the form of a 'Bertie & Betty Bin's' shaped like monsters, and arrange specific collection days. They pay more per tonne of these goods as there is higher re-use of the goods.

Government legislation

There is some confusion around the term "waste" with regards to textiles: if general public donate clothes to the charity shop, it is not waste. If that donation can not be re-sold within the shop, and the organisation is unable to sell the goods to a rag merchant, then it becomes waste. To conduct legitimate business in the waste industry, a company needs to register with a waste carrier licence, failure to do so results in imprisonment or fine. Some companies recycle textiles but do not register. Should the government ensure that reputable rag trade merchants are involved or influence the destination of clothes donated to charity shops?

The fashion design industry

Issues around donation of clothing have social/political as well as environmental concerns. Second hand market in clothing has raised complex issues regarding the local economy: some parts of the population have developed successful businesses while others find their business (usually in design/manufacture) cannot compete with the lower priced, often better quality and trendier imports (Fields, 2000 and Mhango and Niehm 2005). Retailers such as TK Max have done a service as they sell items that at one time may have been destined for landfill.

Implications for fashion design

- Work is being undertaken on ways in which shoes can be recycled/made ecologically.
- Designers should not use polyester: it does not decompose, is not suitable to be worn in hot climates, but tends to be the fibre of choice for the corporate wear companies. Having worked with a major airline company for 15 years, LMB now advises them at the conception stage of their uniform.
- To enable reuse/recycle, use natural fibres e.g., wool and cotton or a mixture; one of the only uses for polyester fabrics is by cement mixer companies for scraping inside the mixer.
- LMB also re-design using in house designers and items that can not be re-used as a garment, selling through their own shop on Brick Lane, the term they use is up-cycling. They have also helped new businesses by sponsoring them by giving them access to textile products, once they are more established they sell them the materials they need by weight (www.lmb)
- There are a growing number of designers currently working on developing fashion design reusing discarded clothing. There are a number of ways in which they are marketing their designs, for example the Fashioning an Ethical Industry and also the Esthetical umbrella organisation that shows at London Fashion Week.

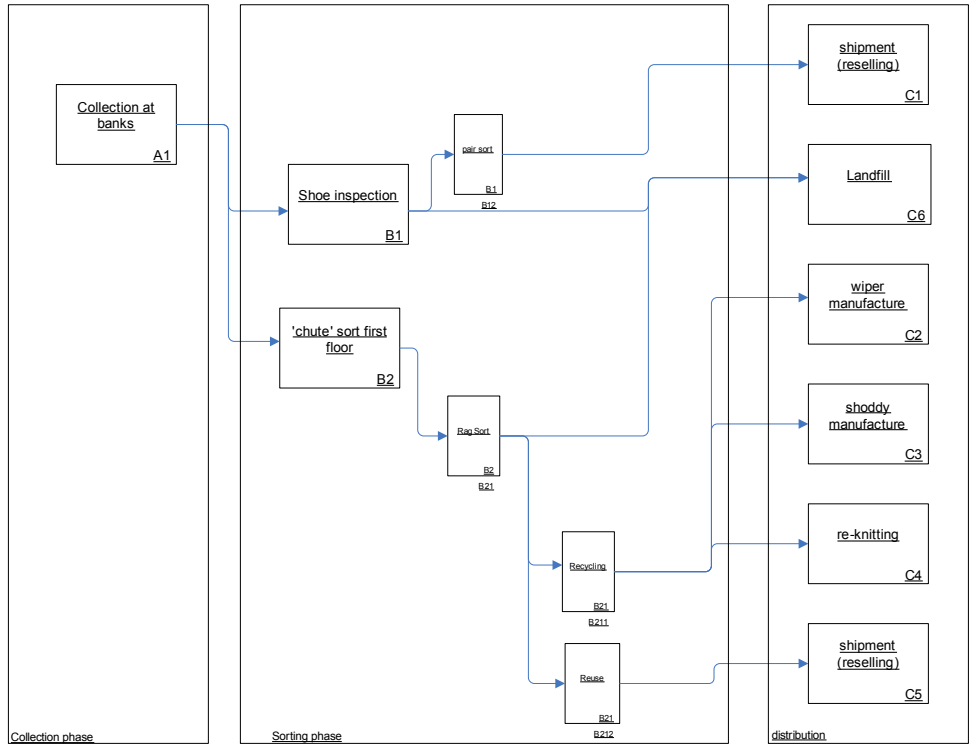

Figure 2: a summary of the textile recycling process at LMB and Co.

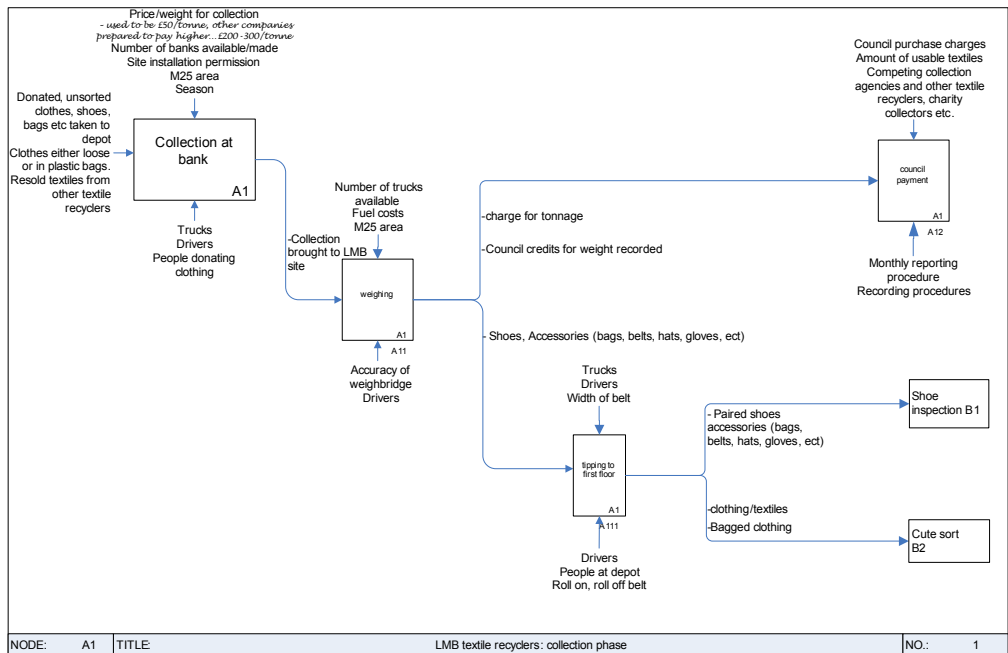

Figure 3: collection phase at LMB and Co.

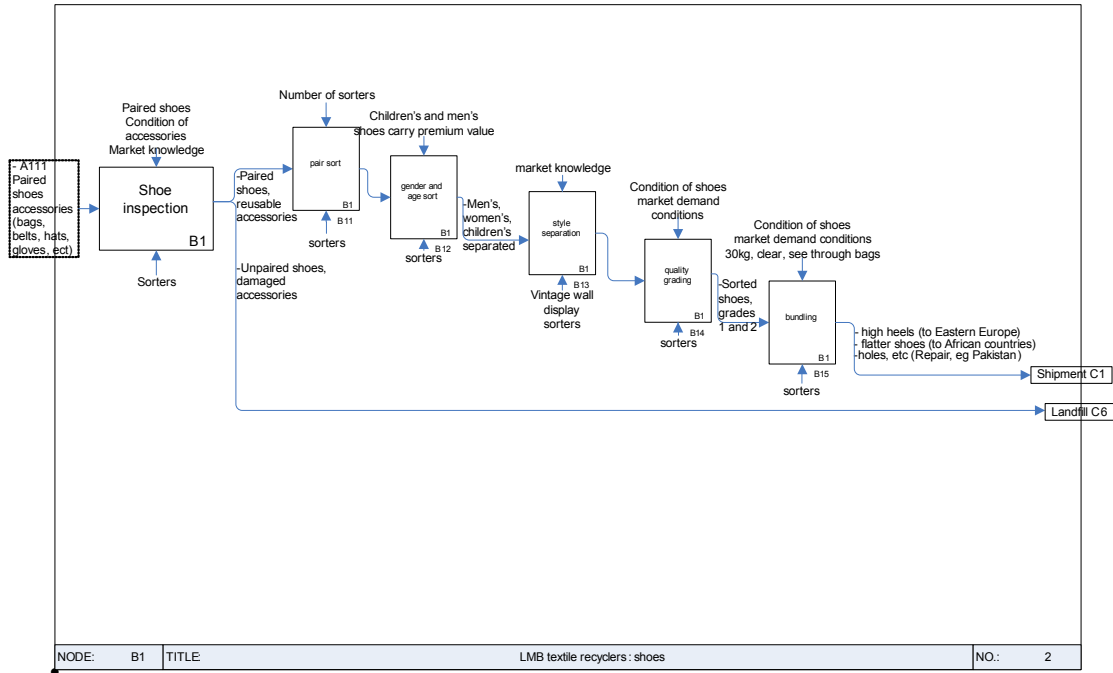

Figure 4(i): sorting phase at LMB and Co.: shoes

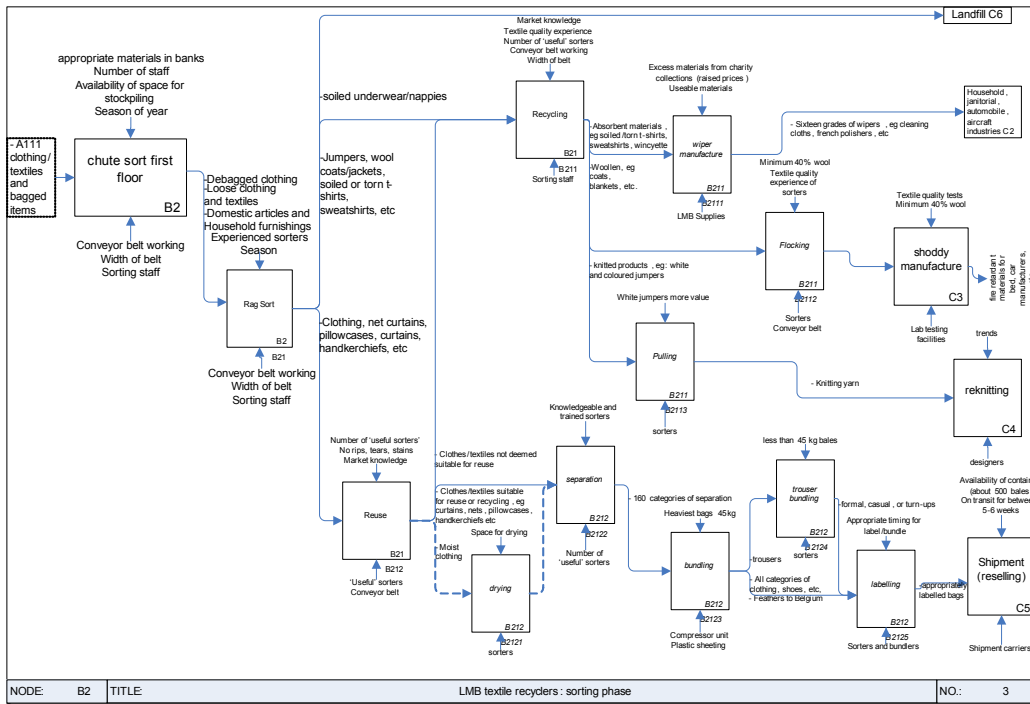

Figure 4(ii): sorting phase at LMB and Co.: textiles products

REFERENCES:

BIN AKASAH, Z., A. and BIN AMIRUDIN, R. (2006), "Maintenance management process model for school buildings: an application of IDEF0 modelling methodology", The International Conference on Construction Industry 2006 (ICCI, Universitas Bung Hatta. Padang. INDONESIA July 2006

DEFRA (2006) *Recycling of Low Grade Clothing Waste* Conducted by Oakdene Hollins Ltd, the Salvation Army Trading Company Ltd and Nonwovens Innovation & Research Institute Ltd.

FIELD, S. (2000) *The Internationalisation of the Second-Hand Clothing Trade: The Case of Zimbabwe*. Unpublished PhD Thesis, African Studies Centre, Coventry University: UK.

- FORUM FOR THE FUTURE and Marks and Spencer (2007) *Fashioning Sustainability: A review of the sustainability impacts of the clothing industry*, UK.
- MADSEN, JACOB, HARTLIN, BRYAN, PERUMALPILLAI, SHAHILA, SELBY, SARAH AND AUMÔNIER, SIMON. (2007). *Mapping of Evidence on Sustainable Development Impacts that Occur in Life Cycles of Clothing: A Report to the Department for Environment, Food and Rural Affairs*. Environmental Resources Management (ERM) Ltd. Defra, London.
- MHANGO, M., W., and NIEHM, L., S. (2005), "The second-hand clothing distribution channel: Opportunities for retail entrepreneurs in Malawi", *Journal of Fashion Marketing and Management*, Volume 9 Number 3 2005 pp. 342-356, Emerald Group Publishing Limited
- TUKKER, HUPPES, GUINÉE, HEIJUNGS, DE KONING, VAN OERS, SUH, GEERKEN, VAN HOLDERBEKE, JANSEN, AND NIELSEN (2006), *Environmental Impact of Products (EIPRO): Analysis of the life cycle environmental impacts related to the final consumption of the EU-25*, Technical Report EUR 22284 EN, European Commission.
- UNIVERSITY OF CAMBRIDGE INSTITUTE FOR MANUFACTURING (2006) *Well dressed? The present and future sustainability of clothing and textiles in the United Kingdom*, University of Cambridge
www.defra.gov.uk/environment/consumerprod/products/clothing.htm, "Product roadmaps – Clothing", November 2008.
www.lmb.co.uk/design.php, "design projects", November 2008.

Acknowledgements

The authors would like to express their thanks to Oakdene Hollins who have sponsored the research presented in this paper.

Corresponding Author Contact

¹ Dr Clare HUSSEY
Clothing Industry Research
47 Whitley Road
Whitley Bay
Tyne And Wear
NE26 2EP
cjhussey@googlemail.com

0779 3892859
0191 2903816
<http://clothingindustryresearch.co.uk>

² Dr Pammi SINHA
The University of Manchester
Textiles and Paper Group
School of Materials
University of Manchester
PO Box 88
Manchester M60 1QD
pammi.sinha@manchester.ac.uk
0161 306 4190
<http://www.materials.manchester.ac.uk/aboutus/staff/pammisinha>